

LIGHT BAR HARNESS KIT



P/N 2882320

APPLICATION

The Light Bar Harness Kit is compatible with multiple lighting accessories (sold separately) and various models of vehicles. Verify accessory compatibility and fitment at Polaris.com or at your local Authorized Polaris Dealer.

BEFORE YOU BEGIN

Read these instructions and check to be sure all parts and tools are accounted for. Please retain these installation instructions for future reference and parts ordering information.

KIT CONTENTS

This Kit includes:

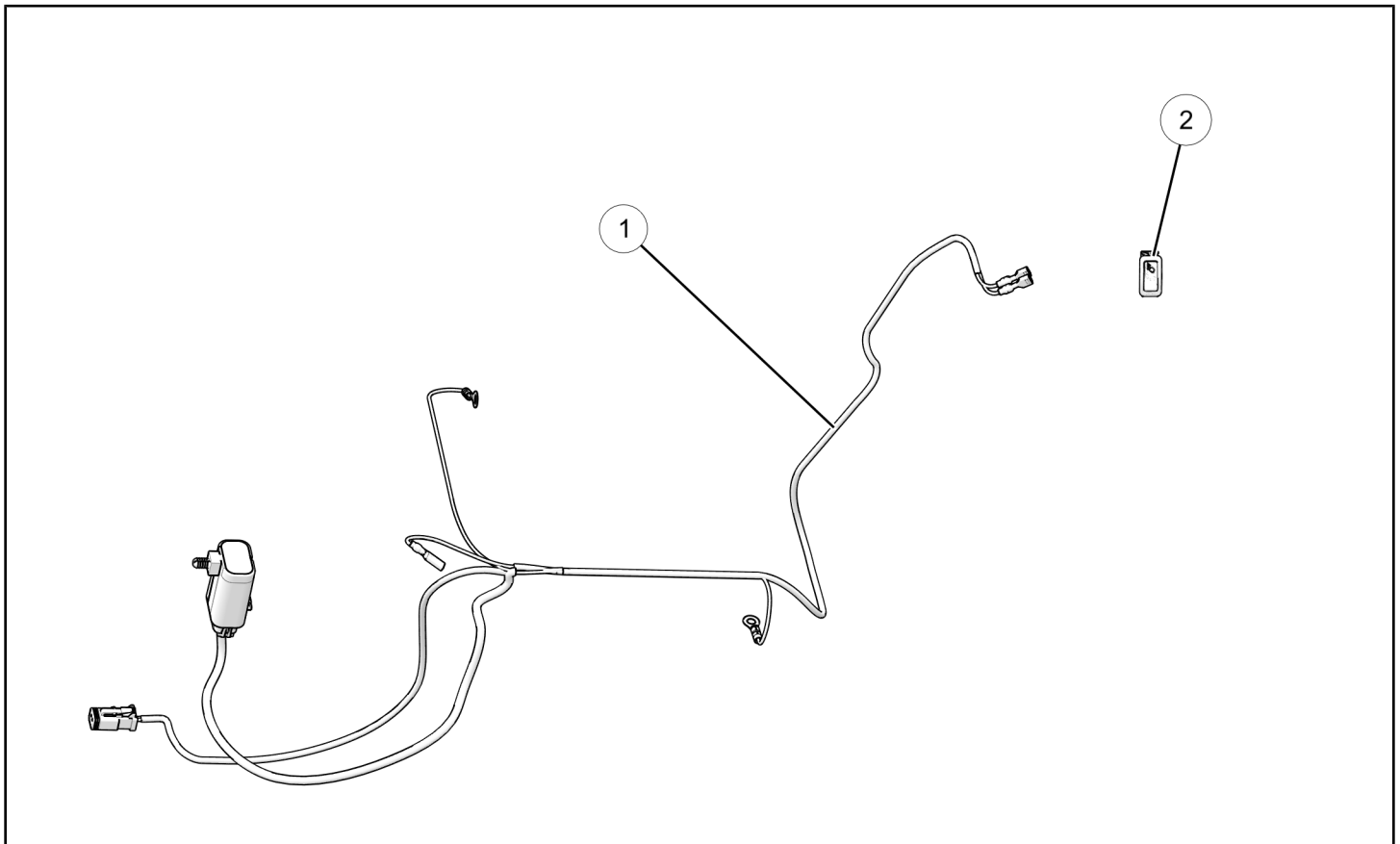

REF	QTY	PART DESCRIPTION	PART NUMBER
1	1	Harness - Light Bar, ATV	4016684
2	1	Switch - Work Light, ON/OFF	4011074
	1	Instructions	9927746

TOOLS REQUIRED

- Safety Glasses
- Pliers, Side Cutting
- Socket Set, Metric
- Socket Set, Torx® Bit

- Wrench Set, Metric
- Drill
- Drill Bit: 1/4"
- Cable Ties

IMPORTANT

Your Light Bar Harness Kit is exclusively designed for your vehicle. Please read the installation instructions thoroughly before beginning. Installation is easier if the vehicle is clean and free of debris. For your safety, and to ensure a satisfactory installation, perform all installation steps correctly in the sequence shown.

ASSEMBLY TIME

Approximately 36 minutes

NOTE

Additional time may be required for optional steps, or to accommodate other installed accessories.

INSTALLATION INSTRUCTIONS

Ensure vehicle is parked on a flat surface and vehicle is stable prior to installation. Shift vehicle transmission into "PARK". Lock the parking brake and turn key to "OFF" position and remove from vehicle.

2. Remove battery cover panel (C).

Sportsman XP models will require the removal of two screws (D).

GAIN ACCESS

1. Open front storage bin cover (A).

Sportsman XP models remove front storage bin (B).

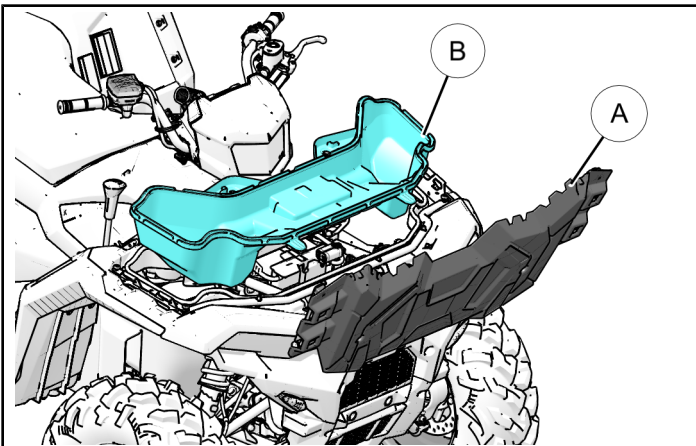

Sportsman 570 models do not have a removable front storage bin. For Sportsman 570 models you will only need to remove the front storage bin gasket.

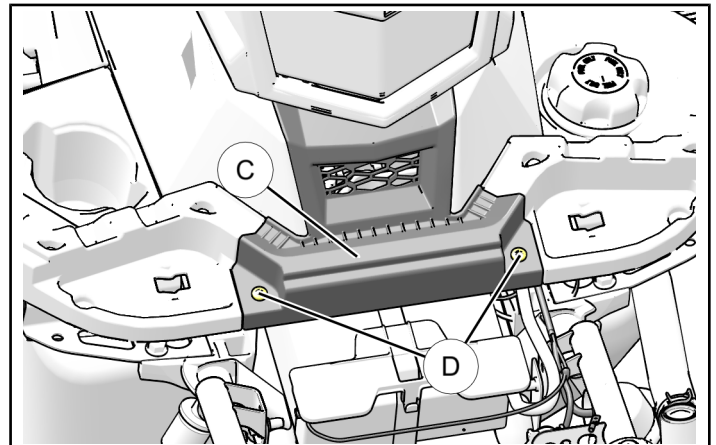

Sportsman 570 models will require the removal of four screws (D) shown below.

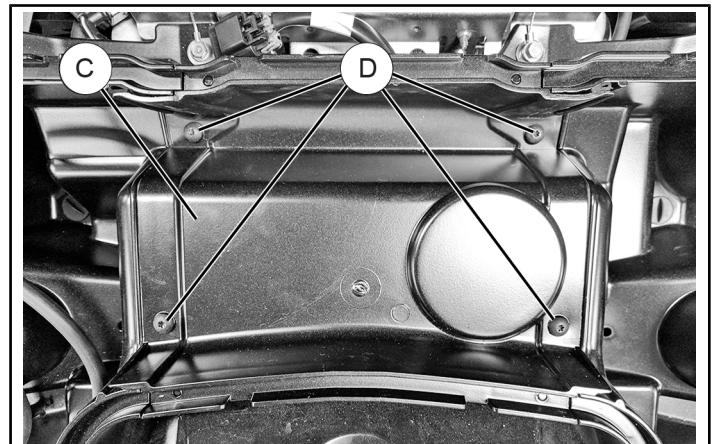

3. Remove the front section (E) of the headlight/instrument pod cover by removing four screws (F). There are two screws on the rear section and one screw on each side of the front section of the cover. This step is the same for all models.

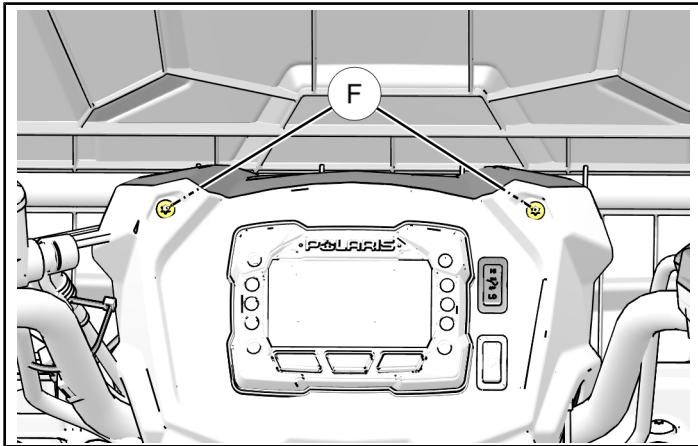
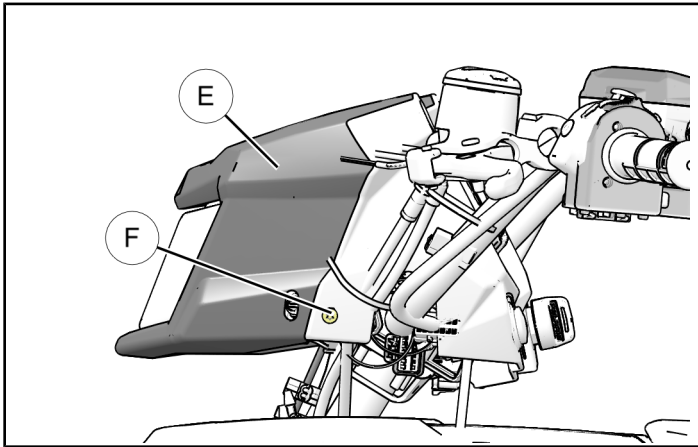

4. Next, remove the rear section of the headlight/instrument pod (G).

For **Sportsman XP** models remove the remaining three screws (H) and disconnect all necessary electrical connections.

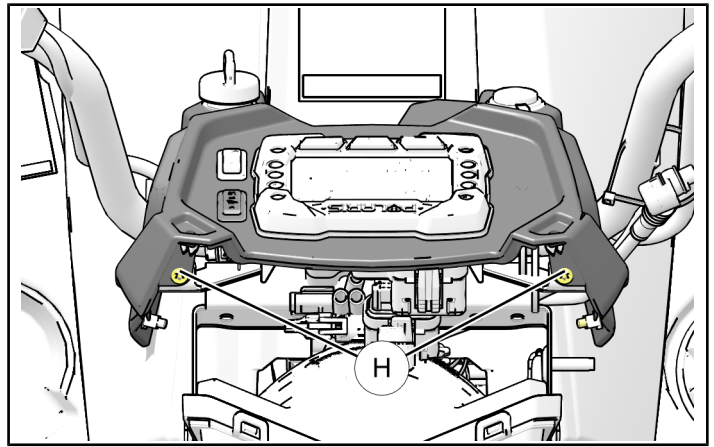
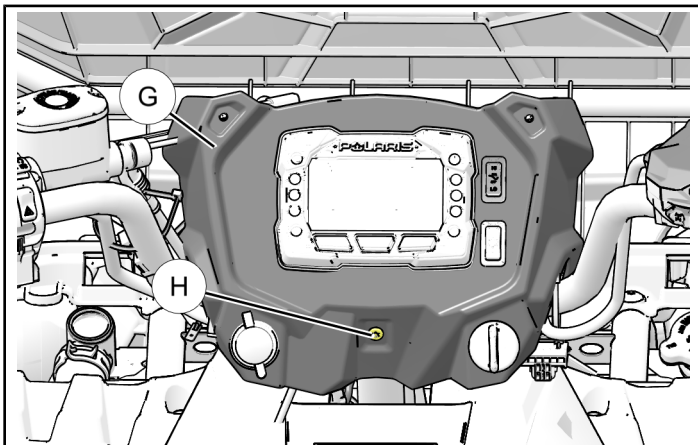

NOTE

It is recommended to label all similar electrical connections as you disconnect them to ensure proper reassembly.

Sportsman 570 model headlight/instrument pod screw locations shown below.

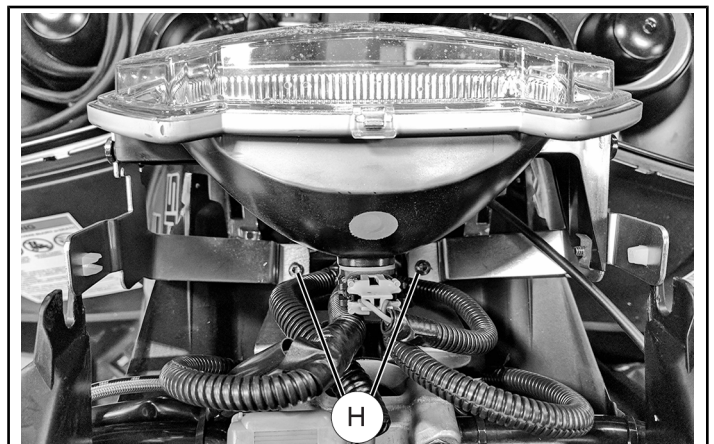
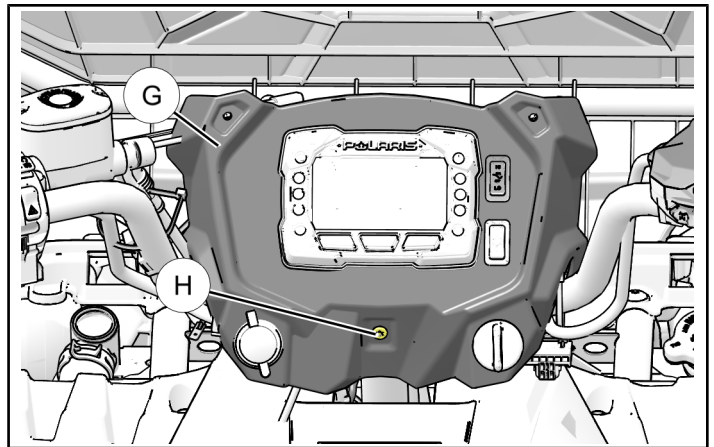

SWITCH INSTALLATION

This procedure is the same for all vehicles

1. Using a sharp knife, carefully cut out one rectangular switch blank ① from rear facing portion of headlight pod cover as shown.

NOTE

Any open location may be used.

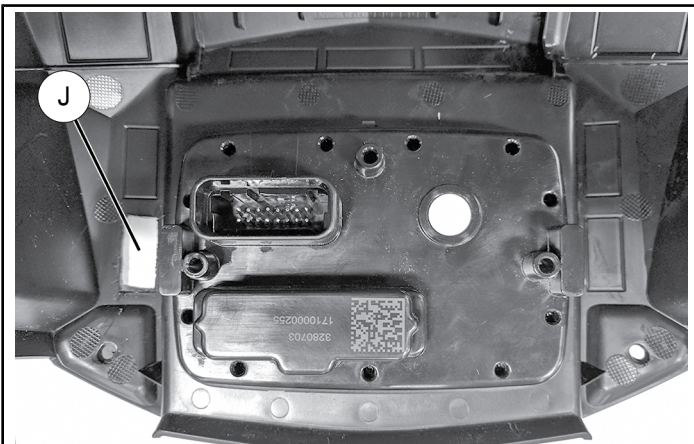
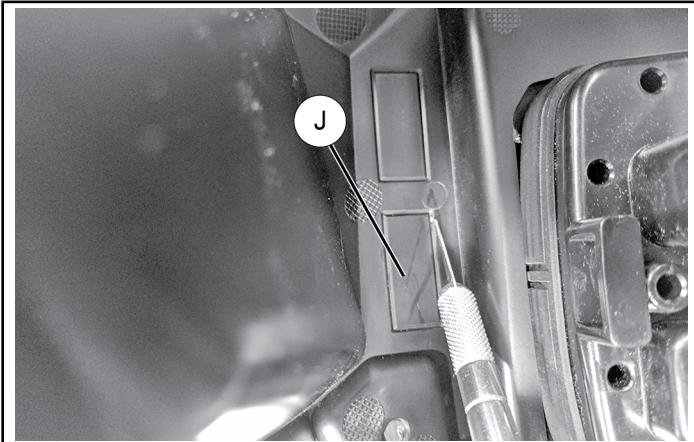

2. Install switch ② into open location, then connect the two female terminals ③ of harness to switch as shown.

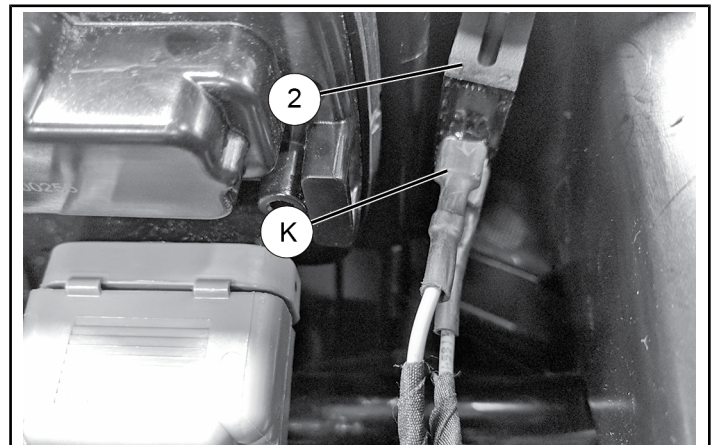
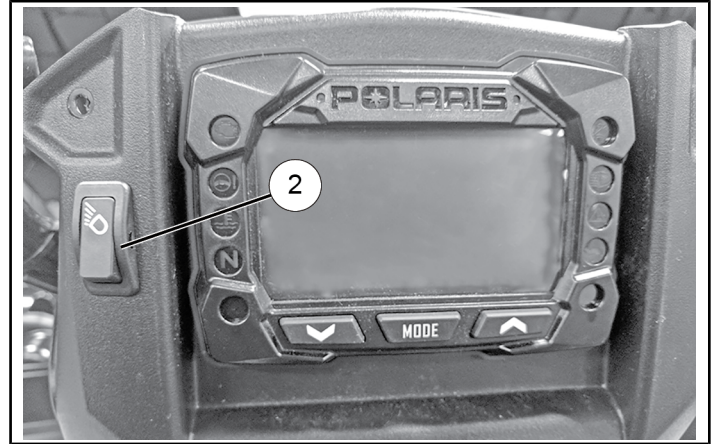

3. Reconnect the headlight pod electrical connections you previously disconnected.
4. Route harness switch wire down towards battery compartment and reinstall front and rear headlight/instrument pod cover using retained screws.

HARNESS INSTALLATION

SPORTSMAN 570 MODELS

1. Disconnect black negative (-) cable from battery.

⚠ WARNING

ALWAYS disconnect black negative (-) cable from battery **FIRST**. Failure to comply will result in a high current electrical arc, and may result in battery explosion if tool touches grounded frame. Death or serious injury may occur.

2. Using a 1/4" drill bit, drill a mounting hole **(M)** for the fuse relay in the approximate location shown. Once finished, secure the fuse relay **(L)** into position by pushing the fir tree clip into the mounting hole.

IMPORTANT

Control drill depth to prevent damage to underlying structure or components.

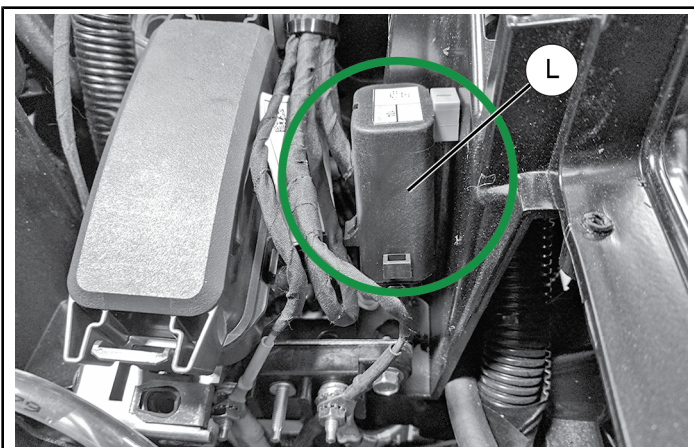
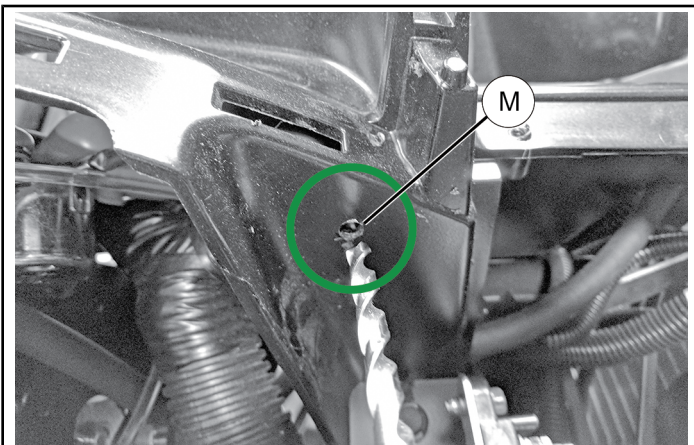

3. Connect the following light bar harness ring terminals to terminal block:
 - **“BATT”/RED** harness wire ring terminal **(P)**: To post with existing RED battery connection cable (unswitched 12V POS); post may be identified as **“BAT”**
 - **“GND”/BLACK/BROWN** harness wire **(N)**: To post with existing BLACK battery connection cable (12V NEG); post may be identified as **“GND”**

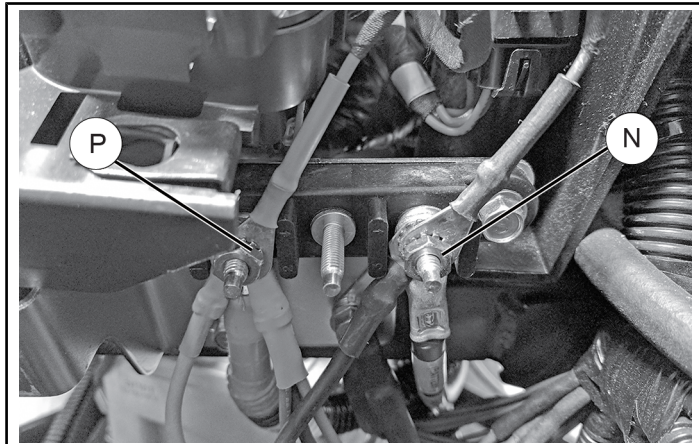

4. Join the male keyed power terminal (orange/white strip) **(Q)**, to matching female terminal (orange/white or orange wire) on main harness.

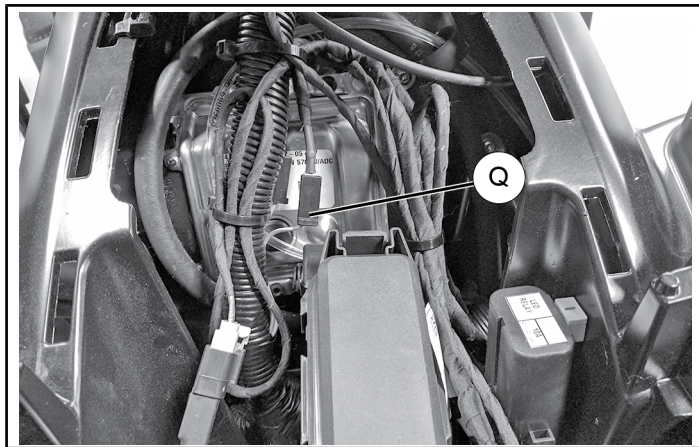

- Route LED connection over to matching light bar connection. Location **Ⓡ** may vary depending on lighting accessory installed. Approximate location shown below for reference.

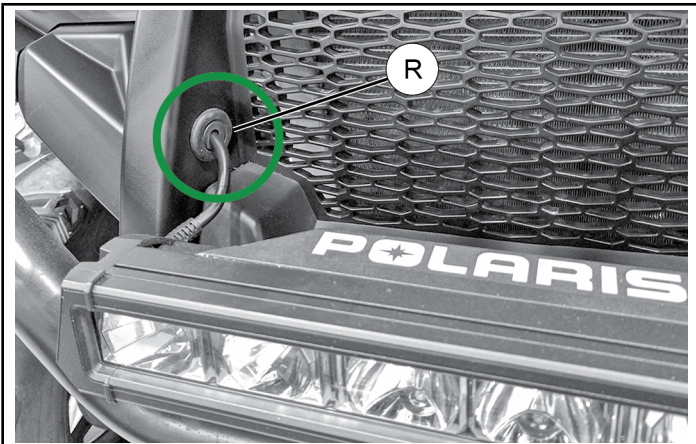

- Secure all wires in place using cable ties.

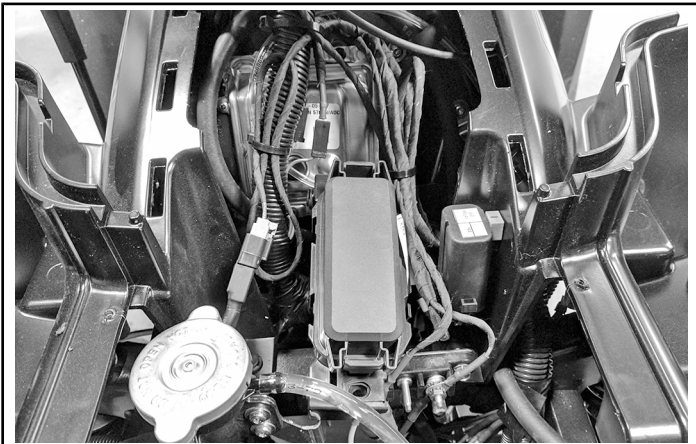

IMPORTANT

Ensure wires are free from all pinch points and secured away from all moving parts to avoid damage to electrical harness and connected components.

- Reconnect black negative (-) cable to battery.
- Replace all previously removed components. Close and secure front storage bin cover.

SPORTSMAN XP MODELS

- Disconnect black negative (-) cable from battery **FIRST** then disconnect red positive (+) cable.

⚠ WARNING

ALWAYS disconnect black negative (-) cable from battery **FIRST**. Failure to comply will result in a high current electrical arc, and may result in battery explosion if tool touches grounded frame. Death or serious injury may occur.

- Install fuse relay **Ⓛ** as shown by pushing the fir tree clip into the predrilled hole on the outermost edge of the front left shock tower and use a cable tie to secure into position.

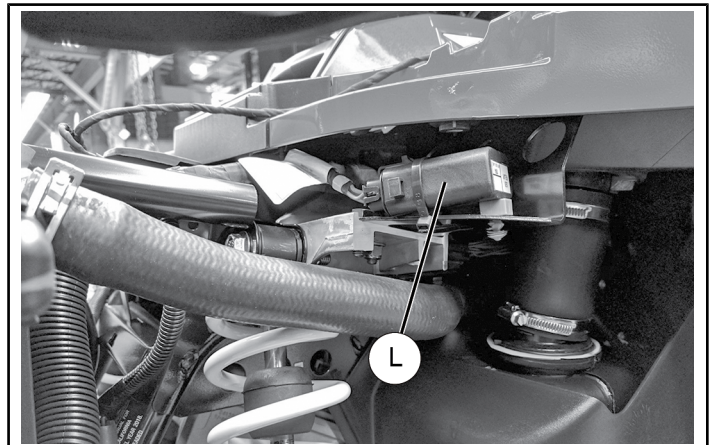

- Connect the following light bar harness ring terminals to battery:

- **“BATT”/RED** harness wire ring terminal **Ⓟ**: To positive (+) post (12V POS) on battery along with all other wires previously removed from the red (+) battery post/terminal.
- **“GND”/BLACK/BROWN** harness wire **Ⓝ**: To negative (-) post (12V NEG) on battery along with all other wires previously removed from the black (-) battery post/terminal.

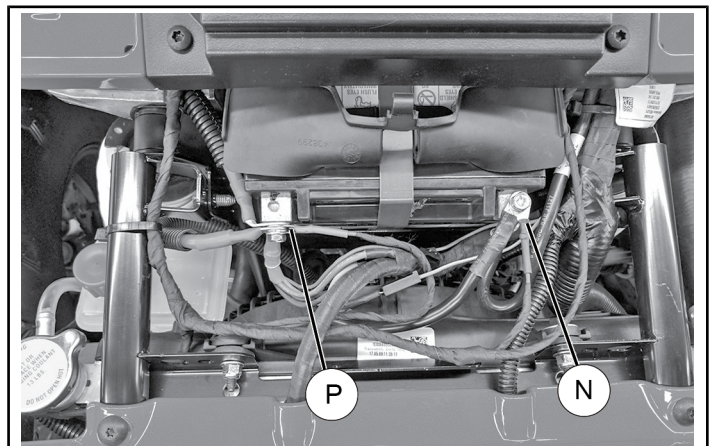

4. Join the male keyed power terminal (orange/white strip) ①, to matching female terminal (orange/white or orange wire) on main harness.

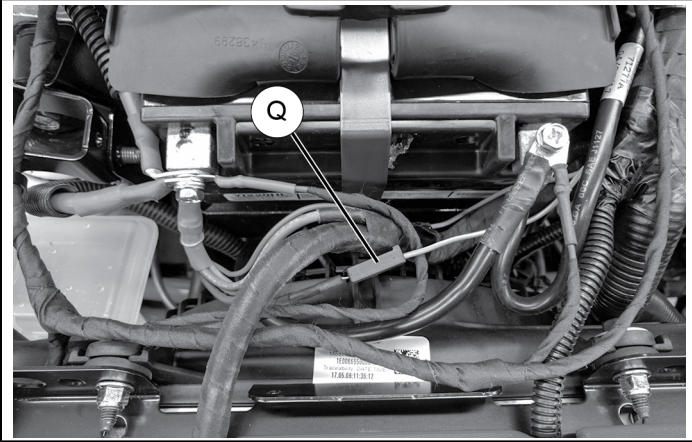

5. Route LED connection over to matching light bar connection. Location ② may vary depending on lighting accessory installed. Approximate location shown below for reference.

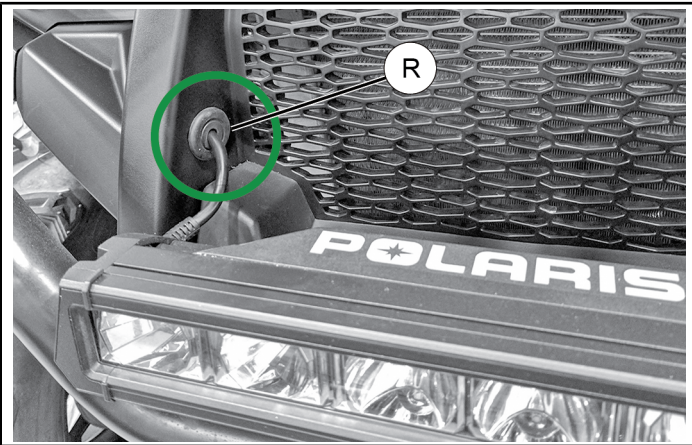

6. Secure all wires in place using cable ties.

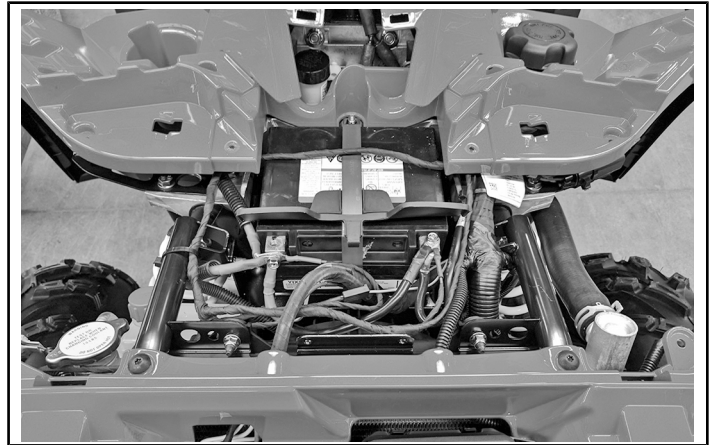

IMPORTANT

Ensure wires are free from all pinch points and secured away from all moving parts to avoid damage to electrical harness and connected components.

7. Replace all previously removed components. Close and secure front storage bin cover.

FEEDBACK FORM

A feedback form has been created for the installer to provide any comments, questions or concerns about the installation instructions. The form is viewable on mobile devices by scanning the QR code or by clicking [HERE](#) if viewing on a PC.

